

Mobile Sit-Stand Desk

STSCART



*actual product may vary from photos

FR: Guide de l'utilisateur - fr.startech.com

DE: Bedienungsanleitung - de.startech.com

ES: Guía del usuario - es.startech.com

NL: Gebruiksaanwijzing - nl.startech.com

PT: Guia do usuário - pt.startech.com

IT: Guida per l'uso - it.startech.com

For the latest information, technical specifications, and support for this product, please visit www.StarTech.com/STSCART.

Use of Trademarks, Registered Trademarks, and other Protected Names and Symbols

This manual may make reference to trademarks, registered trademarks, and other protected names and/or symbols of third-party companies not related in any way to StarTech.com. Where they occur these references are for illustrative purposes only and do not represent an endorsement of a product or service by StarTech.com, or an endorsement of the product(s) to which this manual applies by the third-party company in question. Regardless of any direct acknowledgement elsewhere in the body of this document, StarTech.com hereby acknowledges that all trademarks, registered trademarks, service marks, and other protected names and/or symbols contained in this manual and related documents are the property of their respective holders.

Warning statements

Make sure that you assemble this product according to the instructions.

Read the entire manual and make sure that you understand the instructions before you start to assemble and use this product.

Do not allow children to climb on this product or use this product without proper supervision.

This product is intended for indoor use only and should not be used outdoors.

Do not move the cart over cords, cables, or uneven surfaces.

Before you start to move the cart, make sure that you unlock the casters.

Do not exceed the weight capacity of this product. Overloading this product might result in injury or property damage. This product can support the following weight: 50 kg (110 lb.).

Make sure that the equipment mounted on the workstation is secure before you move the workstation up or down. If the equipment is not secured, it could fall off the workstation as you move it and the equipment could be damaged.

Exercise caution when you raise the desktop because it can move with force and cause personal injury or damage to your equipment.

Varningsmeddelanden

Se till att du monterar produkten i enlighet med instruktionerna.

Läs hela manualen och se till att du förstår instruktionerna innan du börjar montera och använda produkten.

Låt inte barn klättra på produkten eller använda produkten utan uppsikt.

Produkten är endast avsedd för användning inomhus och ska inte användas utomhus.

Flytta inte vagnen över kablar eller ojämna ytor.

Innan du börjar flytta på vagnen, se till att hjulen är upplåsta.

Överskrid inte produktens viktkapacitet. Överbelastning av produkten kan orsaka skada på person eller egendom. Denna produkt kan stötta följande vikt: 50 kg.

Se till att utrustningen som är monterad på arbetsstationen är säkrad innan du flyttar den upp eller ner. Om utrustningen inte är säkrad kan den ramla av arbetsstationen när du flyttar den och utrustningen kan skadas.

Var försiktig när du höjer bordet eftersom det kan röra sig med kraft och orsaka personskada eller skada på utrustning.

Waarschuwingen

Zorg dat u dit product volgens de instructies in elkaar zet.

Lees de gehele handleiding en zorg dat u de instructies begrijpt voordat u dit product in elkaar zet en gebruikt.

Geef kinderen geen toestemming om op dit apparaat te klimmen of dit product zonder goed toezicht te gebruiken.

Dit product is alleen bedoeld voor binnengebruik en mag niet buiten worden gebruikt.

Rijd de vagen niet over snoeren, kabels of ongelijke oppervlakken.

Voordat u de vagen gaat vervangen, moet u de zwenkwielen ontbrengden.

Overstrijd de maximale capaciteit van dit product niet. Overbelasting van dit product kan letsel of materiële schade veroorzaken. Dit product kan het volgende gewicht ondersteunen: 50 kg.

Zorg ervoor dat uw apparaten goed aan uw werkstation bevestigd zijn voordat u uw werkstation naar boven of beneden beweegt. Als uw apparaten niet vastgezet zijn kunnen ze vallen op het moment dat u het werkstation beweegt, met als gevolg dat uw apparaten kunnen beschadigen.

Wees voorzichtig bij het omhoog zetten van het bureaublad, het blad komt krachtig omhoog en daarbij kunt u zich bezemen of beschadigen aan uw apparatuur veroorzaken.

注意

必ず取扱説明書に従って本製品の組み立てを行ってください。

最初に取扱説明書を最後まで読み、本製品の組み立て方をすべて理解してから組み立て作業を始めてください。

本製品で小さなお子様が乗って遊ばないようにして下さい。お子様が使用する際には、適切な監視を怠らないようにして下さい。

本製品は、室内での使用を想定しています。戸外では使用しないで下さい。

コードやケーブルの上、または凹凸のある床面にカートを移動させないで下さい。

カートを動かす前に、キヤスタのロックが解除されているか確認して下さい。

本製品で定められた最大積載重量を超えないようにして下さい。最大積載重量をオーバーした場合は、怪我をする恐れや器物破損の恐れがあります。本製品は、以下の重量まで対応できます：50 kg。

ワークステーションを上下に動かす前に、備え付けのロック機構がしっかりと固定されていることを確認して下さい。備え付けられたワークステーションが固定されていない状態で動かした場合、部品がワークステーションから落下し損傷する可能性があります。本製品は、以下の重量まで対応できます：50 kg。

デスクトップの上昇時には、ガススプリングに蓄えられたエネルギーによりデスクトップが上昇するため、事故や器物破損が起こらないよう十分注意して下さい。

Dichiarazioni di avvertenza

Assicurarsi di Assemblare il prodotto secondo le istruzioni.

Leggere l'intero manuale e assicurarsi di aver compreso tutte le istruzioni prima di iniziare ad assemblare e utilizzare questo prodotto.

Non consentire ai bambini di arrampicarsi sul prodotto o di utilizzarlo senza un'adeguata supervisione.

Il prodotto è destinato all'uso in ambienti interni. Se ne sconsiglia l'impiego in ambienti esterni.

Non far passare il carrello sopra corde, cavi o superfici irregolari.

Prima di procedere allo spostamento del carrello, verificare di aver sbloccato le rotelle.

Non superare la capacità di carico del prodotto. Il sovraccarico del prodotto potrebbe causare danni o lesioni. Il prodotto è in grado di sostenere il seguente peso: 50 kg.

Assicurarsi che l'attrezzatura montata sulla stazione di lavoro siano fissate prima di sollevare o abbassare la stessa. Se l'attrezzatura non è fissa potrebbe cadere dalla stazione di lavoro e provocare dei danni.

Esercitare cautela quando si alza il desktop, perché può muoversi con forza e causare lesioni personali o danni alle apparecchiature.

Avertissements

Assemblez ce produit conformément aux instructions.

Lisez tout le manuel et assurez-vous que vous comprenez les instructions avant de commencer à assembler et utiliser ce produit.

N'autorisez pas les enfants à grimper sur ce produit ni à l'utiliser sans surveillance.

Ce produit est uniquement destiné à une utilisation en intérieur et ne doit pas être utilisé à l'extérieur.

Ne faites pas rouler le meuble sur des cordons, des câbles ou des surfaces inégales.

Avant de déplacer le meuble, veillez à débloquer les roulettes.

Ne dépassez pas la capacité pondérale du produit. Une surcharge du produit peut entraîner des blessures ou des dommages matériels. Ce produit peut supporter : 50 kg.

Assurez-vous que l'équipement est fixé sur le poste de travail de manière sécurisée avant de le lever ou l'abaisser. Si l'équipement n'est pas sécurisé, il peut se tomber du poste de travail lorsque vous le déplacez et vous risquez de l'endommager.

Nous vous recommandons de faire attention lorsque vous levez le bureau car la force développée lors de ce mouvement pourrait vous blesser ou bien occasionner des dommages matériels.

Mensagens de aviso

Certifique-se de que monta este produto de acordo com as instruções.

Leia todo o manual e certifique-se de que entende as instruções antes de começar a montar e a utilizar este produto.

Não deixar as crianças trepar neste produto ou utilizar este produto sem a devida supervisão.

Este produto destina-se apenas a uma utilização no interior e não deve ser utilizado no exterior.

Não mova o carro pelos fios, cabos ou superfícies irregulares.

Antes de começar a mover o carro, certifique-se de que desbloqueia os rodízios.

Não exceda a capacidade de peso deste produto. Sobrecarregar este produto pode resultar em ferimentos ou danos de propriedade. Este produto pode suportar o seguinte peso: 50 kg.

Certifique-se de que o equipamento montado na estação de trabalho está seguro antes de mover a estação de trabalho para cima ou para baixo. Se o equipamento não estiver seguro, pode cair abaixo da estação de trabalho quando o mover e o equipamento pode ficar danificado.

Tenha cuidado quando levantar a superfície de secretária porque pode movimentar-se com a força e provocar ferimentos pessoais ou danos no seu equipamento.

Advertencias de uso

Asegúrese de ensamblar este producto según las instrucciones.

Lea todo el manual y asegúrese de haber comprendido bien las instrucciones antes de proceder con el ensamblaje y el uso de este producto.

No permita que los niños se suban a este producto o que lo utilicen sin la debida supervisión de un adulto.

El uso de este producto es solo para interiores y no debe utilizarse en exteriores.

No desplace el carrito encima de cables o superficies desniveladas.

Antes de empezar a mover el carrito, asegúrese de haber desbloqueado las ruedas.

Asegúrese de no exceder la capacidad de peso de este producto. La sobrecarga de este producto puede causar lesiones personales o daños en la propiedad. Este producto tiene capacidad para el siguiente peso: 50 kg.

Asegúrese de que el equipo instalado en la estación de trabajo está asegurado antes de moverla hacia arriba o hacia abajo. Si el equipo no estuviera asegurado, podría caerse de la estación de trabajo al desplazarla y podría averiarse.

Tenga cuidado al levantar el escritorio, debido a que este se puede mover con fuerza y en consecuencia causar heridas personales o daños en sus equipos.

Warnhinweise

Beachten Sie bei der Montage dieses Produkts die Montageanweisungen.

Bevor Sie dieses Produkt montieren und verwenden, lesen Sie das gesamte Handbuch und vergewissern Sie sich, dass Sie die Anweisungen verstanden haben.

Gestatten Sie Kindern nicht, auf das Produkt zu klettern oder das Produkt ohne Aufsicht zu benutzen.

Dieses Produkt ist nur zum Gebrauch in Innenräumen vorgesehen und sollte nicht im Freien verwendet werden.

Bewegen Sie den Wagen nicht über Leitungen, Kabel oder unebenes Gelände.

Stellen Sie sicher, dass die Rollen entriegelt sind, bevor Sie den Wagen in Bewegung setzen.

Überschreiten Sie nicht die Tragkraft dieses Produkts. Ein Überladen dieses Produkts kann zu Verletzungen oder zur Beschädigung des Produkts führen. Dieses Produkt ist für die nachstehende Tragkraft ausgelegt: 50 kg.

Stellen Sie sicher, dass Ihre Geräte auf der Arbeitsstation gesichert sind, bevor Sie diese hoch und runter bewegen. Sollten die Geräte nicht gesichert sein, könnten diese von der Arbeitsstation fallen und beschädigt werden, wenn Sie die Arbeitsstation bewegen.

Selen Sie vorsichtig wenn Sie den Desktop bewegen, dieser kann schnell fallen wenn Sie ihn anheben, und Verletzungen oder Schaden an Ihrem Equipment verursachen.

Table of Contents

Warnings	i
Product dimensions	1
Product diagram	2
Technical specifications	3
Package contents	4
Assembly	7
Attach the casters to the base	7
Attach the column to the desktop.....	9
Attach the column assembly to the base assembly	11
Using the mobile sit-stand desk	12
Lock the locking casters.....	13
Manage your cables	14
Technical support	15
Warranty information	15

Product dimensions

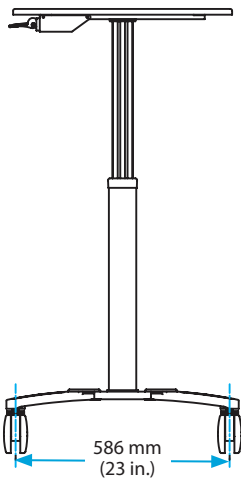
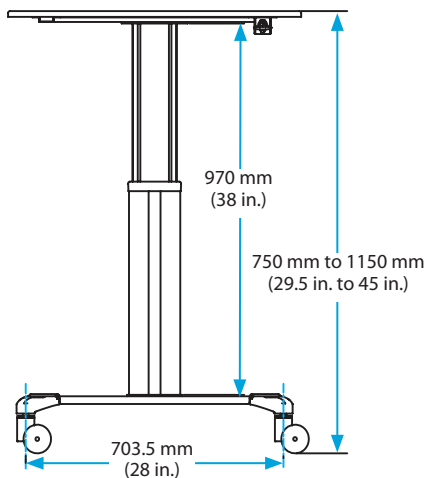
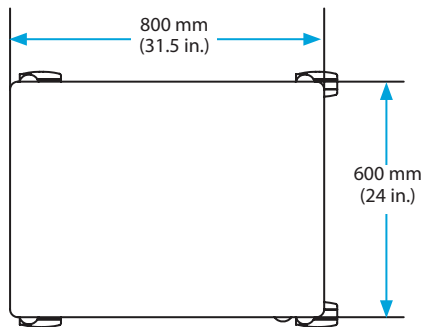

Product diagram

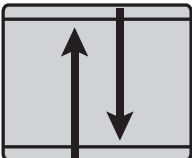
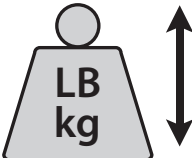
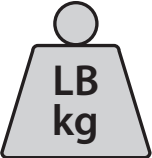

Technical specifications

Type of measurement	Measurement
 <p>Lift</p>	400 mm (16 in.)
 <p>Lift capacity</p>	4.5 kg (10 lb.) Note: If you add more than 4.5 kg of weight to the desktop, you will need to exert some manual force to raise the desktop.
 <p>Static load capacity</p>	50 kg (110 lb.)

Package contents

1

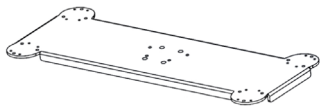

Base
Qty: One

2

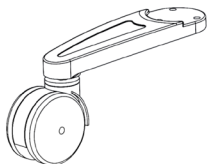

Casters
Qty: Two

3

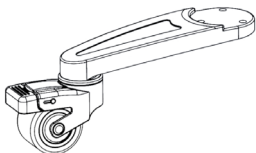

Locking casters
Qty: Two

4



Column
Qty: One

5



Desktop
Qty: One

6



Covers
Qty: Four

7

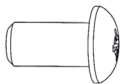

M6x15 mm round-head screws

Qty: Eight

8

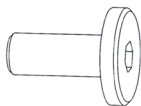

M6x15 mm flat-head screws

Qty: Twelve

9



M4 hex key

Qty: One

10



M5 hex key

Qty: One

11

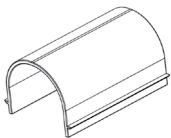

Cable clips

Qty: Four

12



Keys

Qty: Two



Instruction manual

Qty: One

Assembly

Attach the casters to the base

Tip! The back edge of the base is labeled on the underside of the base.

1. Position one of the non-locking casters in line with the assembly holes in one corner of the back edge of the base.
2. Insert three of the M6x15 mm flat-head screws through the top of the base and into the caster. (*figure 1*)

figure 1

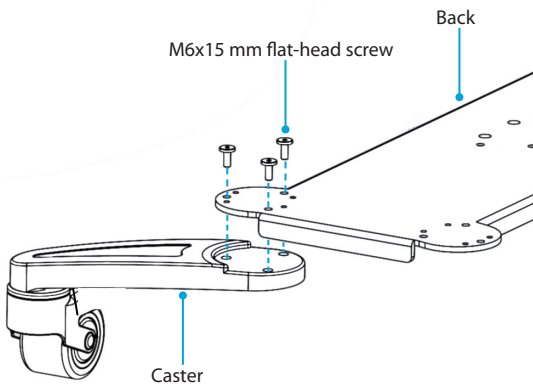

3. Use the M4 hex key to tighten the screws. (figure 2)

figure 2

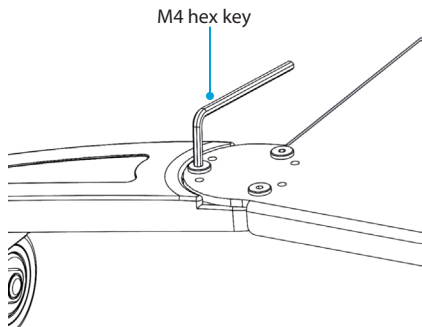

4. Repeat steps 1 to 3 to attach the second non-locking caster to the other corner of the back edge of the base.
5. Repeat steps 1 to 3 to attach the locking casters to the front corners of the base. (figure 3)

figure 3

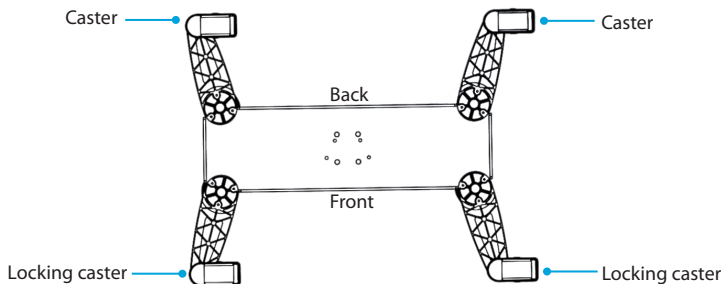

6. Snap a cover over all four corners of the base. (figure 4)

figure 4

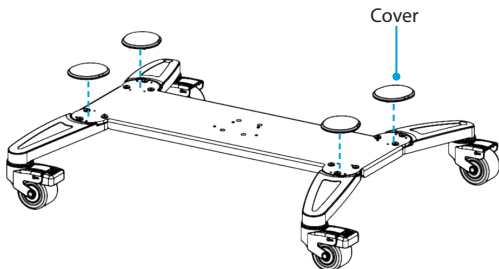

Attach the column to the desktop

The desktop includes a wire cable with an end connector that you use to connect to the spring release in the column.

1. Turn over the desktop so that the underside is facing up.
2. Position the column so that the side labeled "Back" is laying on the back side of the desktop. (figure 5)

Note: The edge of the desktop with the adjustment lever is considered the front of the desktop and the opposite edge is considered the back.

figure 5

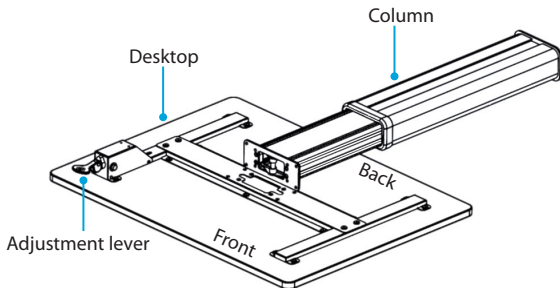

3. Place the end connector attached to the wire cable into the circular opening in the spring release in the column.
4. Thread the wire cable through the opening in the spring release and along the circular projection. (figure 6)
5. Snap the wire into the tab on the other side of the spring release. (figure 7)

figure 6

figure 7

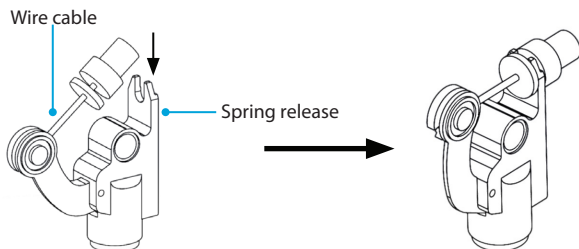

6. Lift the column up and line up the assembly holes in the column with the holes on the underside of the desktop.
7. Insert four of the M6x15 mm round-head screws through the column and into the desktop. (figure 8)
8. Use the M5 hex key to tighten the screws.

figure 8

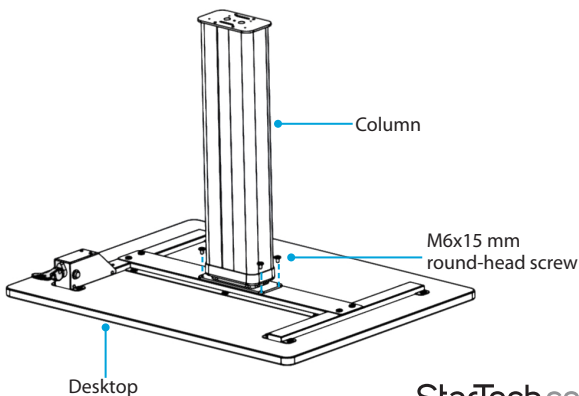

Attach the column assembly to the base assembly

1. Position the base assembly so that the front of the base is in line with the front of the desktop.
2. Insert four of the M6x15 mm round-head screws through the base assembly and into the column assembly. (*figure 9*)

figure 9

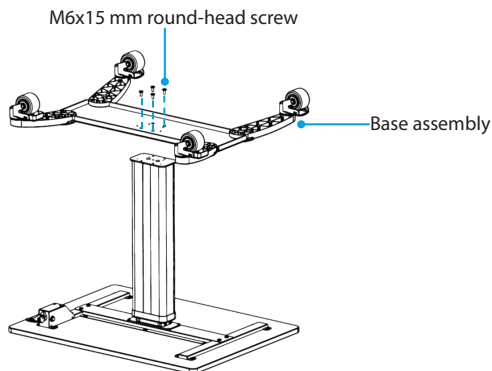

3. Use the M5 hex key to tighten the screws.
4. Carefully turn the assembly over.
5. Use the M5 hex key to remove the safety screw from the back of the column (*figure 10*).

figure 10

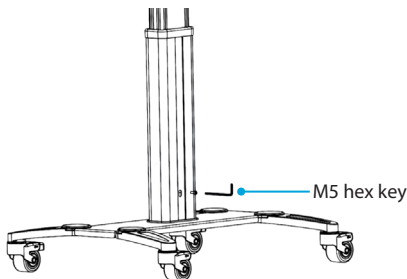

Using the mobile sit-stand desk

Move the desktop up or down

Warning! Before you move the desktop up or down, make sure that the equipment on the desktop is secure. If your equipment is not stable, it could fall off of the desktop as you move it and the equipment could be damaged.

Warning! Exercise caution when you raise the desktop because it can move with force and cause personal injury or damage to your equipment.

Caution! Before you raise the desktop, make sure that the cables you're using are long enough to accommodate the increased height.

Do any of the following:

- To raise the desktop, squeeze the adjustment lever located on the right side of the desktop. (figure 11)
- To lower the desktop, squeeze the adjustment lever and push down on the desktop.
- To lock the adjustment lever so that the desktop can't be raised or lowered, insert one of the provided keys into the lock on the side of the adjustment lever and turn the key counterclockwise.

figure 11

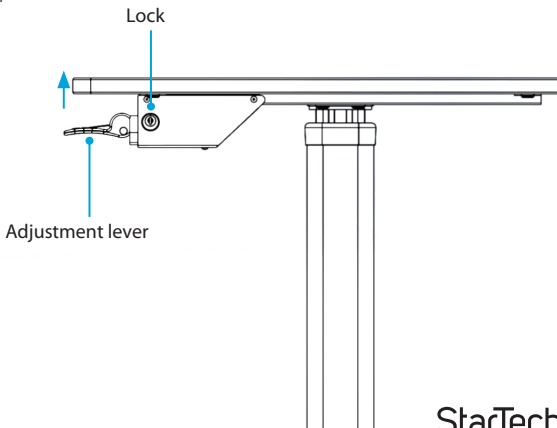

Lock the locking casters

- To prevent the mobile sit-stand from moving, press the locking pedals located on the two locking casters at the front of the mobile sit-stand. (figure 12)
- Press the black tabs on the locking casters to release the locking pedals.

figure 12

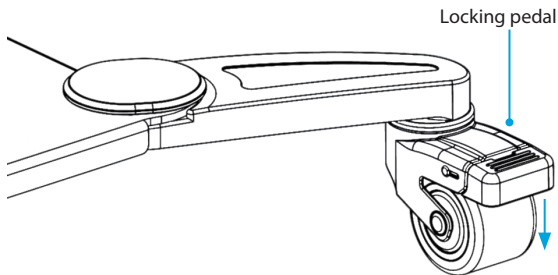

Manage your cables

1. Snap the cable clips into the grooves located on the bottom half of the column at the back or front of the mobile sit-stand.
2. Position your cables down the column and through the cable clips. (figure 13)

figure 13

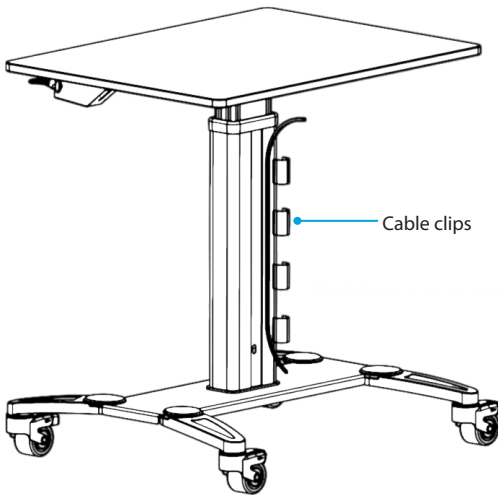

Technical support

StarTech.com's lifetime technical support is an integral part of our commitment to provide industry-leading solutions. If you ever need help with your product, visit www.startech.com/support and access our comprehensive selection of online tools, documentation, and downloads.

For the latest drivers/software, please visit www.startech.com/downloads

Warranty information

This product is backed by a two-year warranty.

StarTech.com warrants its products against defects in materials and workmanship for the periods noted, following the initial date of purchase. During this period, the products may be returned for repair, or replacement with equivalent products at our discretion. The warranty covers parts and labor costs only. StarTech.com does not warrant its products from defects or damages arising from misuse, abuse, alteration, or normal wear and tear.

Limitation of liability

In no event shall the liability of StarTech.com Ltd. and StarTech.com USA LLP (or their officers, directors, employees or agents) for any damages (whether direct or indirect, special, punitive, incidental, consequential, or otherwise), loss of profits, loss of business, or any pecuniary loss, arising out of or related to the use of the product exceed the actual price paid for the product. Some states do not allow the exclusion or limitation of incidental or consequential damages. If such laws apply, the limitations or exclusions contained in this statement may not apply to you.

Hard-to-find made easy. At StarTech.com, that isn't a slogan. It's a promise.

StarTech.com is your one-stop source for every connectivity part you need. From the latest technology to legacy products — and all the parts that bridge the old and new — we can help you find the parts that connect your solutions.

We make it easy to locate the parts, and we quickly deliver them wherever they need to go. Just talk to one of our tech advisors or visit our website. You'll be connected to the products you need in no time.

Visit www.startech.com for complete information on all StarTech.com products and to access exclusive resources and time-saving tools.

StarTech.com is an ISO 9001 Registered manufacturer of connectivity and technology parts. StarTech.com was founded in 1985 and has operations in the United States, Canada, the United Kingdom and Taiwan servicing a worldwide market.